



Technical Data:	
Dimensions	997 x 790 x 799 mm
Connected Load	10.4 kW
Voltage	415 3 Phase AC
Recommended Fuses	3 x 20 A
Frequency Range	50 Hz
Soft Water Connection	DN 20 (R 3/4" inside)
Water Connection	DN 20 (R 3/4" inside)
Water Pressure	200 - 600 kPa (2 - 6 bar)
Drain Connection	DN 50
Gastronorm 1/1 (530 x 325 mm)	6 (max. 65 mm deep)
FlexiRack® (530 x 650 mm)	6 (max. 65 mm deep)
Plates Ø 28 cm on FlexiRack® grids	24
Plates Ø 32 cm - plate trolley	22
Gross Weight	160 kg
Heat Emission Latent	1872 W
Heat Emission Sensitive	1248 W

### Product Description:

- FlexiRack® – 50% more cooking capacity.
- ClimaSelect – Humidity and temperature control measurement (= reliable food quality).
- 5 programmable fan speeds for best cooking uniformity.
- Up to 100 individual cooking programmes can be stored in up to 6 steps.
- 316 S11 durable hygienic cooking chamber. EasyLoad crosswise insertion.
- Handshower.
- DynaSteam2 – It speeds up the cooking process and saves energy.
- Integrated heat exchanger.
- WaveClean – Automatic cleaning system.
- USB interface.
- 3 years warranty parts and labour.

### Installation requirements:

- Soft Water / Water supply / Connection to waste water provided by customer.
- If mineral content is high, reverse osmosis system may be advisable.

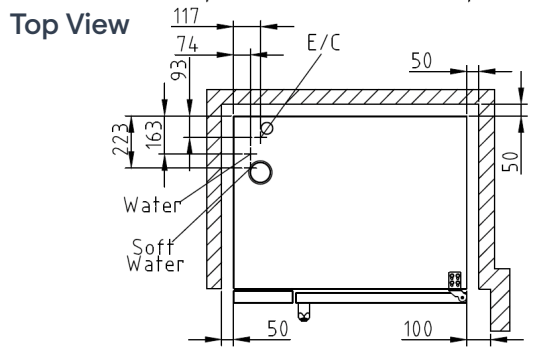
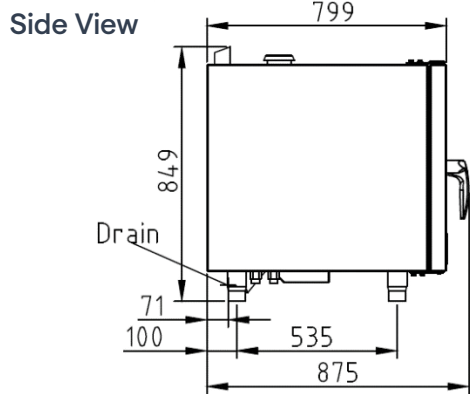
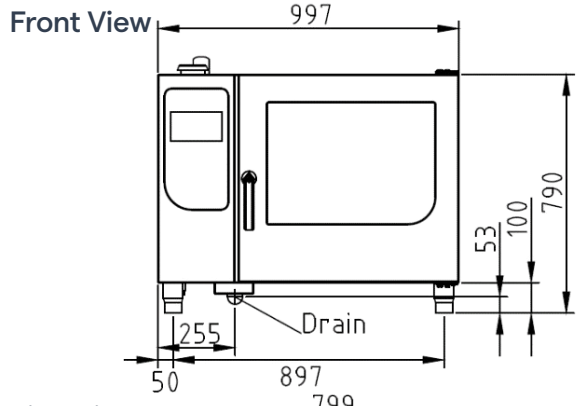

### Accessories:

