



Technical Data:	
Dimensions	550 x 1815 x 840 mm
Connected Load	2 x 7.8 kW
Voltage	2 x 415 3 Phase AC
Recommended Fuses	3 x 20 A + 3 x 20 A
Frequency	50 Hz
Soft Water Connection	DN 20 (R 3/4" inside)
Water Connection	DN 20 (R 3/4" inside)
Water Pressure	200 - 600 kPa (2 - 6 bar)
Drain Connection	DN 40
Gastronorm 1/1 (530 x 325 mm)	6+6 (max. 60 mm deep)
Plates Ø 28 cm	12+12
Material Housing	1.4301
Material Cooking chamber	1.4301
Net Weight	120 kg
Consumption Steaming	7.5 L/h
Consumption Cleaning	1.3 L

Product Description:

- MagicPilot – Robust, wear-free, capacitive true colour touch screen.
- Video assist – Interactive user assistance with clips featuring professional chefs & USB interface.
- CombiDoctor – Self-diagnosis programme. Hygienic rounded corners and cooking chamber door with insulated triple glazing.
- RackControl – Multi-timer.
- GreenInside – Indicates the energy and water consumption for each cooking programme.
- AutoChef – Up to 350 individual cooking programmes and manual operating system.
- High speed centrifugal steam generation technology with heat recovery.
- ClimaSelect – Humidity and temperature control measurement.
- WaveClean – Automatic cleaning system.
- 3 years warranty parts and labour.

Installation requirements:

- Soft Water / Water supply / Connection to waste water provided by customer.
- If mineral content is high, reverse osmosis system may be advisable.



Front View

Side View

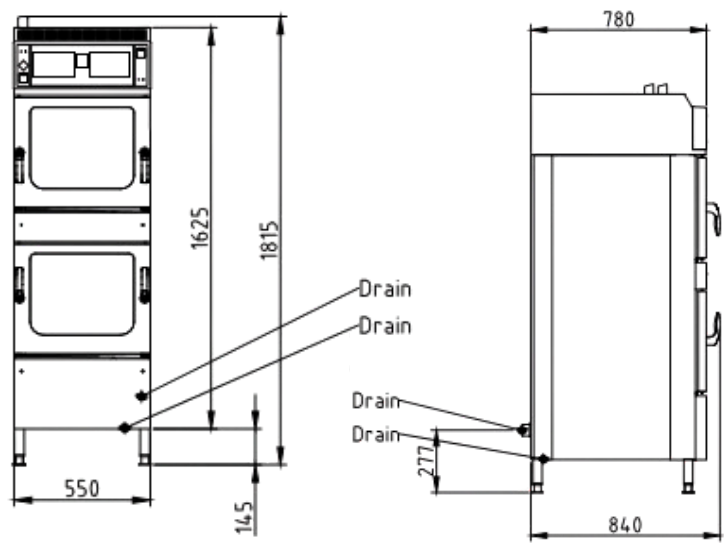

Top View

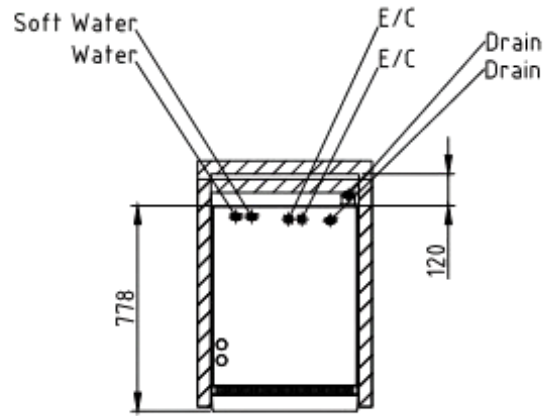

Optional Accessories:

