



#### Product Advantages:

- Hob with 2 heating zones 3.0 kW each.
- Housing made completely stainless steel.
- Tightly welded top plate with lateral drain channels for easy cleaning.
- Hob 320 x 555 mm, 18 mm thick.
- Hob made of heat resistant stainless steel or alternatively chrome plated with antireflection coating.
- Highly efficient contact heating elements.
- Easy to clean hob due to corner radii.

#### Installation requirements:

- Electrical supply provided by customer.

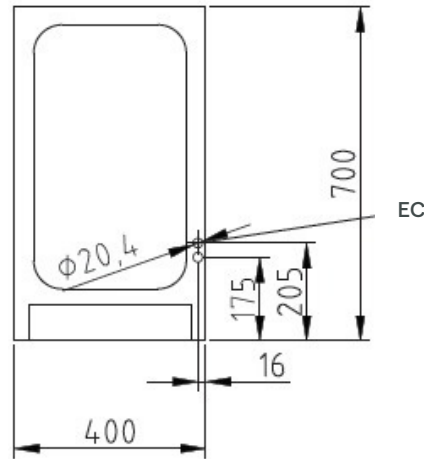
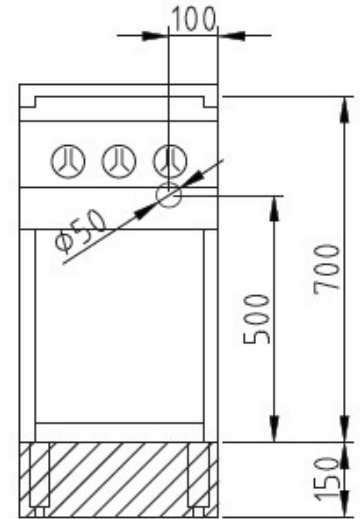

#### Technical Data:

Width x Height x Depth (mm)	400 x 700 (900) x 700
Effective area	2
Dim.: effect. Area (mm)	320 x 555
Connected load (elect.) (kW):	6.0
Voltage (V) / EC:	415 3 phase AC
Recommended fuses (A):	3 x 16
Net weight (kg):	65
Gross weight (kg):	70
Heat emission latent (W):	480
Heat emission sensitive (W):	1200
Type of protection:	IPX5

