



#### Product Advantages:

- Heating power infinitely variable.
- Completely electrically wired inside.
- Easy to clean.
- Heating by high output induction generators for fast energy transmission.
- Saves energy due to high efficiency.
- Equipped for installation of a 580 mm high Counter SL lower section with removable appliance feet which are adjustable in height.

#### Installation requirements:

- Electrical power provided by customer.

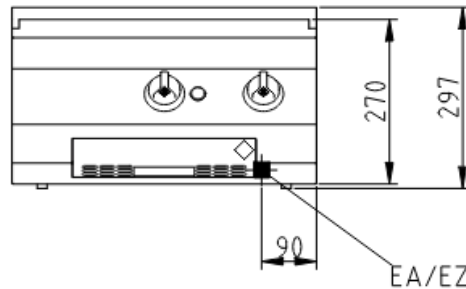
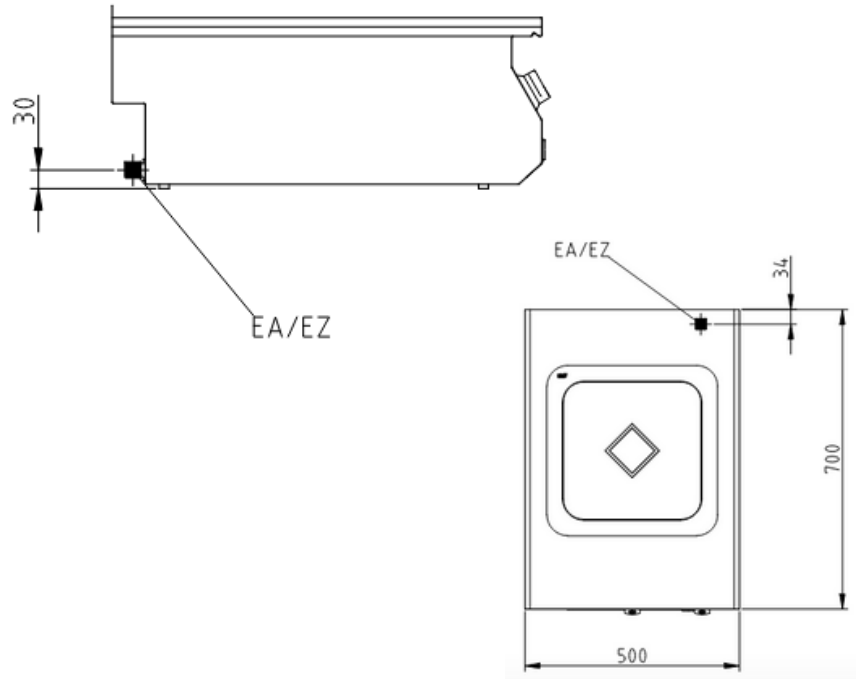

#### Technical Data:

Width x Height x Depth (mm)	500 x 270 x 700 mm
Effective area	1
Dim.: effect. Area (mm)	400 x 400
Connected load (elect.) (kW):	10.0
Voltage (V) / EC:	415 3 phase
Recommended fuses (A):	3 x 32
Frequency range (Hz):	50/60
Net weight (kg):	35
Gross weight (kg):	40
Heat emission latent (W):	800
Heat emission sensitive (W):	700
Type of protection:	IPX4

