



Product Advantages:

- Stainless steel tubular heating elements with a low surface load for longer lasting fat, basin with deeper load and a cool zone.
- Heating elements can be raised completely out of the frying basin, with holding bracket and automatic cut off, for easy cleaning.
- Suited to the every day needs of industrial kitchens.
- Robust and reliable.
- Basket lifting mechanism as standard.
- Lifting motor and emptying system
- Temperature control by precision thermostats with control lamp, main switch and safety temperature limiter.

Installation requirements:

- Electrical supply provided by customer.

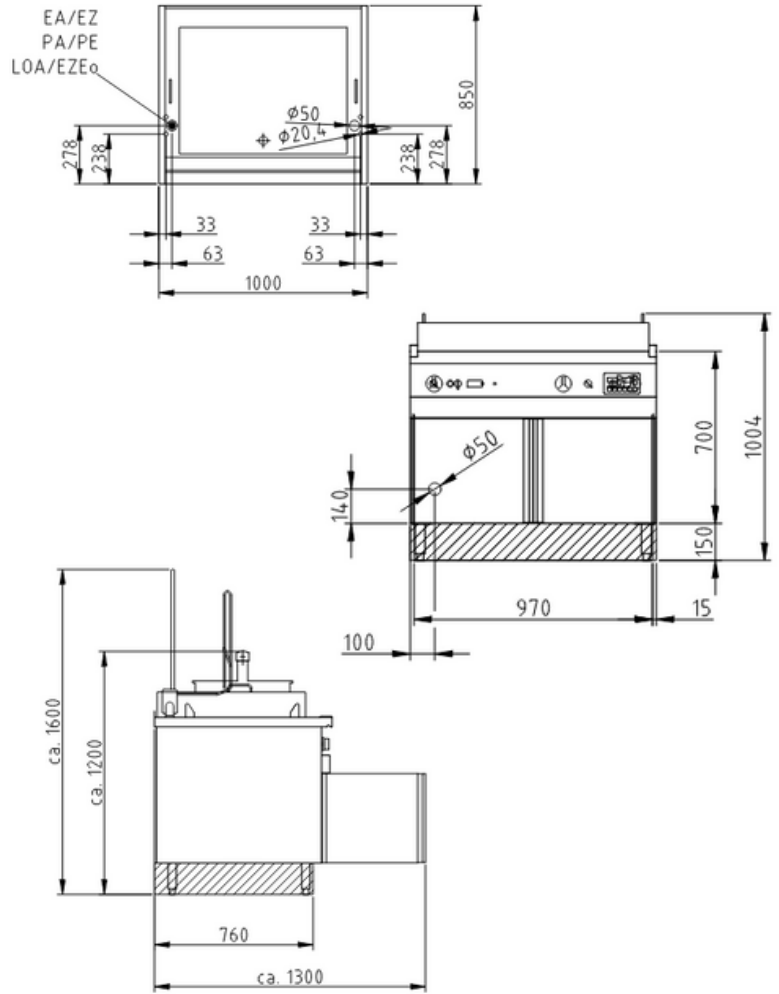

Technical Data:

Width x Height x Depth (mm)	1000 x 700 x 850
Effective area	1
Dim.: effect. Area (mm)	800 x 600 x 270
Nominal capacity (L):	115
Connected load (elect.) (kW):	42
Voltage (V) / EC:	415 3 phase
Recommended fuses (A):	3 x 80
Net weight (kg):	140
Gross weight (kg):	175
Heat emission latent (W):	29400
Heat emission sensitive (W):	3780
Type of protection:	IPX5

